

A Division of the Angelus Corporation  
 Ph (262) 246-0500 Fax (262) 246-0450 www.picwire.com  
 W220N1051 Springdale Road, Waukesha, WI 53186

Approved : *PFT*  
 Distribution : USER

Date : 02/06/03  
 Rev. : 6 (05/18/21)  
 Uncontrolled if Printed

**TNC Bulkhead Jack**  
 for S22089 & UH25107

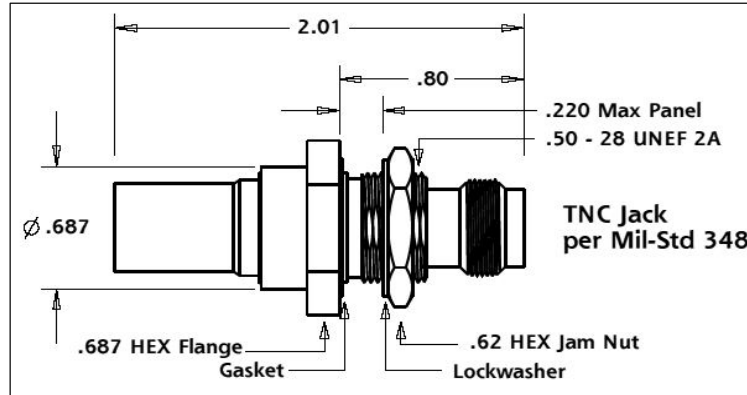

**PERFORMANCE**

Nominal Impedance	50 Ohms
Frequency Range	0 - 12 GHz
Voltage Rating	500 VRMS
Insulation Resistance	5000 Megohms

**CONNECTOR WEIGHT (Each)**

1.31 ounces (37.20 grams)

**RoHS COMPLIANT**

Complies to RoHS Standards

**INSTALLATION**

Recommended Jam Nut Torque - 35 to 40 in. lbs.

**Pic Die Set**

*Center Contact*

M22520 / 5 - 01 Tool,  
 PIC 190418 Hex Crimp Die  
 (.132 hex)

*Crimp Ferrule*

M22520 / 5 - 01 Tool,  
 PIC 190418 Hex Crimp Die  
 (.523/.562 hex)

**MIL Spec Die Set**

*Center Contact*

M22520 / 5-01 Tool,  
 MIL Spec \*M22520 / 5-04  
 (.138 A hex)

*Crimp Ferrule*

M22520 / 5-01 Tool,  
 MIL Spec \*M22520 / 5-27  
 (.532 A hex)

**CONSTRUCTION**

**Materials:**

Body	Brass, ASTM-B16, Alloy UNS 36000, H02
Center Contact	Beryllium Copper, ASTM-B196, Alloy UNS C17300
Ferrule	Brass, ASTM-B16, Alloy UNS 36000, Dead Soft, Weatherseals included
Dielectric	TFE Fluorocarbon, ASTM-D1710, Type 1, Grade 1
Hardware	Jam Nut, Lk WWshr, Grommet

**Finish :**

Body, Ferrule	Nickel
Center Contact	Gold

**Applicable Standards**

MIL-STD 348  
 MIL-PRF-39012

**Notes :**

- 1) A 2.5" piece of Raychem ATUM heat shrink P/N ATUM-19/6-0 provided with connector for purpose of strain relief & moisture protection.
- 2) Please refer to T-190XXX Termination Instruction sheet for strip dimensions & instructions for S22089 & T-UH25107 for UH25107.

\* Note - MIL Spec die to be used on the smaller diameter area of ferrule only. Not the larger "Bell" area on end.