

PIC Wire & Cable	Connector Specification	P/N 190323
<i>A Division of the Angelus Corporation</i> Ph (262) 246-0500 Fax (262) 246-0450 www.picwire.com PO Box 330 Sussex, WI 53089	Approved : 	Date 12/09/97
	Distribution : USER	Rev. 4 (06/17/14) Uncontrolled Document

TNC In-Line Straight Jack
for S33141

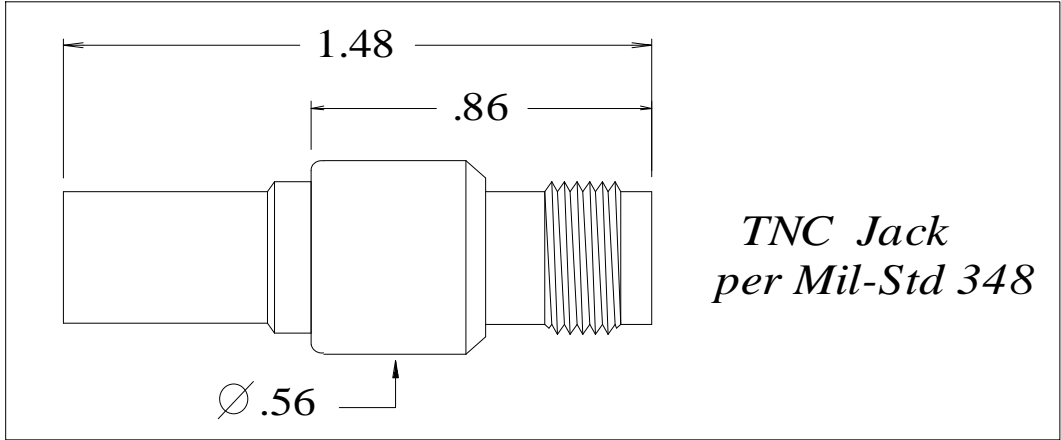

PERFORMANCE

Nominal Impedance	50 Ohms
Frequency Range	0 - 12 GHz
Voltage Rating	500 VRMS
Insulation Resistance	5000 Megohms

CONNECTOR WEIGHT (Each)

.74 ounces (20.98 grams)

RoHS COMPLIANT

Complies to RoHS Standards

INSTALLATION

Pic Die Set	MIL Spec Die Set
<i>Center Contact</i>	<i>Center Contact</i>
M22520 / 5 - 01 Tool, PIC 190318 Hex Crimp Die (.098 hex)	M22520 / 5-01 Tool, MIL Spec *M22520 / 5-29 (.100 B hex)
<i>Crimp Ferrule</i>	<i>Crimp Ferrule</i>
M22520 / 5 - 01 Tool, PIC 190318 Hex Crimp Die (.324/.392 hex)	M22520 / 5-01 Tool, MIL Spec *M22520 / 5-29 (.324 A hex)

* Note - MIL Spec die to be used on the smaller diameter area of ferrule only. Not the larger "Bell" area on end.

CONSTRUCTION

Materials:

Body	Brass, ASTM-B16, Alloy UNS 36000, H02
Center Contact	Beryllium Copper, ASTM-B196, Alloy UNS C17300
Ferrule	Brass, ASTM-B16, Alloy UNS 36000, Dead Soft, Weatherseals included
Dielectric	TFE Fluorocarbon, ASTM-D1710, Type 1, Grade 1

Finish :

Body, Ferrule	Nickel
Center Contact	Gold

Applicable Standards

MIL-STD 348
MIL-PRF-39012

- Notes :**
- 1) A 2.5" piece of Raychem ATUM heat shrink P/N ATUM-16/4-0 provided with connector for purpose of strain relief & moisture protection.
 - 2) Please refer to T-190XXX Termination Instruction sheet for strip dimensions & instructions.